

SICK SinCos Transducer  
SRS/SRM50 (Hiperface)

Resolver And  
Heidenhain  
EBI1118 (EnDat)

Heidenhain  
ECI1319  
EQI1331

Heidenhain  
ECN1313 (EnDat)  
ECN1325 (SIL)  
ERN1385  
EQN1325 (EnDat)  
EQN1337 (SIL)

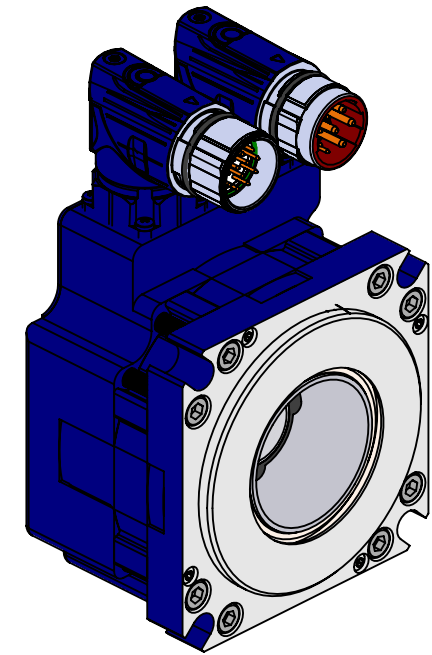
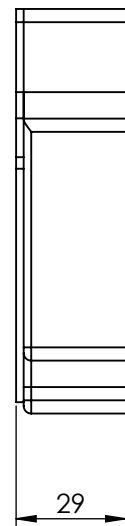
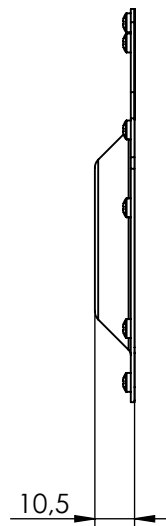
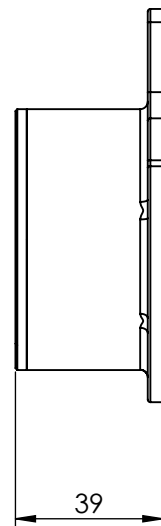

Other feedback options are available upon request.

ICM09		
Type	J	N
L=	59,6	87,3
Incl. Brake L=	85,1	112,7
Specifications can be changed without notice		



DRAWING:

**ICM09 Mechanical Specifications**

**A3**